

ANALYSIS AND DESIGN OF LOW-RISE MASONRY AND CONCRETE WALLS RETROFITTED USING STEEL STRIPS

By Mustafa Taghdi,¹ Michel Bruneau,² and Murat Saatcioglu³

ABSTRACT: Indeterminate truss models are proposed for the analysis of low-rise walls retrofitted using a special system of vertical and diagonal steel strips. An equilibrium diagram is also presented to calculate the ultimate strength of walls based on a lower bound theorem of plasticity. Step-by-step analyses were conducted to establish force-displacement relationships of walls that compared well with those obtained experimentally. A simple retrofit design procedure is formulated and illustrated using a numerical example.

INTRODUCTION

Experimental results presented in a companion paper (Taghdi et al. 2000) demonstrate that the seismic strength and ductility of low-rise walls can be significantly enhanced when retrofitted using a specially detailed system of vertical and diagonal steel strips. This was shown to be equally true for unreinforced masonry, reinforced masonry, and reinforced concrete walls. The mechanism of load resistance in these retrofitted walls is illustrated in this paper through analyses, using simple models that are suitable for an office environment design.

Truss models are developed to investigate the force-displacement relationship of walls retrofitted by steel strips. An equilibrium diagram is presented to calculate the ultimate strength of walls based on a lower bound approach of the theory of plasticity. All models presented here consider the walls to be subjected to an incrementally increasing static lateral loads. Although this approach does not recognize the potential stiffness and strength degradation that would arise under cyclic loading, it can be used to draw the envelope of maximum strengths reached at given displacements throughout the hysteretic response. This backbone of the hysteretic curve provides valuable information for design purposes.

Analytical results obtained using the models presented in this paper compare well with those obtained experimentally. A retrofit design procedure is then formulated and illustrated using a numerical example.

SIMPLE TRUSS MODEL

The simplest model considered here consists of an indeterminate truss having five members, as shown in Fig. 1. Based on the direction of loading shown in the figure, members can be labeled following a numbering scheme. Member 1 is a tension steel member that consists of the vertical steel strip along one edge and the vertical reinforcing bars that may be present at the same location. The member in the plane of the floor or roof [or the top beam present in each of the wall specimens

tested by Taghdi et al. (2000)] is designated as Member 2. The vertical strut in compression, at the other end of the wall, is referred to as Member 3, and its stiffness and strength are defined by considering both the steel strips and a concrete/masonry column of width taken as one-tenth of the wall length. The diagonal strips in tension and compression constitute Members 4 and 5, respectively. Member 5 consists of a concrete/masonry strut with an effective width equal to the diagonal steel strip width. Obviously, Members 1 and 2, as well as 4 and 5, would be respectively swapped if horizontal loading was considered to act in the reverse direction.

A series of elastic push-over analyses is performed using the above truss model. The stiffness and strength of each member is reduced gradually, as appropriate in the step-by-step analysis, to account for degradation due to concrete crushing. The first analysis is conducted to determine all member forces (F_1 , F_2 , F_3 , F_4 , and F_5) and the corresponding lateral deflection Δ in terms of the total applied force V .

The lateral load and the corresponding deflection at first yield are labeled as V_{y1} and Δ_{y1} , respectively. Usually, the compression capacity of Members 3 and 5 is sufficiently large to ensure that tension yielding of Members 1 and 4 occurs first. However, a number of factors must be considered to determine which of those two tension members yields first. These include the type of wall material (concrete or masonry), the area and yield strength of the steel strips, the wall reinforcement layout, and the lateral restraint provided to the longitudinal reinforcing bars by the bolts of the vertical steel strips.

Note that, for Member 1, if the steel strip yield strength is different from that of the reinforcing bars, an additional analysis step is warranted using the same statically indeterminate truss, but discounting those members that have already

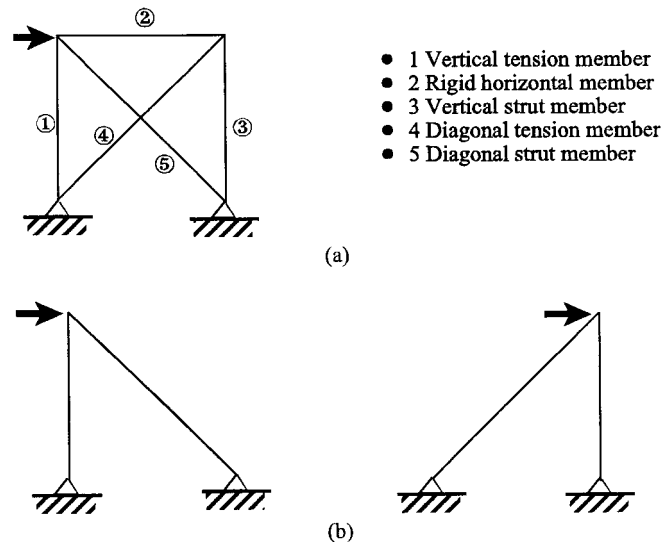

FIG. 1. Simplified Truss Model

¹Postdoctoral Res. Fellow, Ottawa Carleton Earthquake Engrg. Res. Ctr., Dept. of Civ. Engrg., Univ. of Ottawa, ON, Canada K1N 6N5. E-mail: mtaghdi@uottawa.ca

²Deputy Dir., Multidisciplinary Ctr., Earthquake Engrg. Res., and Prof., 130 Ketter Hall, Dept. of Civ., Struct., and Envir. Engrg., State Univ. of New York, Buffalo, NY 14260. E-mail: bruneau@acsu.buffalo.edu

³Prof., Ottawa Carleton Earthquake Engrg. Res. Ctr., Dept. of Civ. Engrg., Univ. of Ottawa, ON, Canada K1N 6N5. E-mail: murat@eng.uottawa.ca

Note. Associate Editor: Walter H. Gerstle. Discussion open until February 1, 2001. Separate discussions should be submitted for the individual papers in this symposium. To extend the closing date one month, a written request must be filed with the ASCE Manager of Journals. The manuscript for this paper was submitted for review and possible publication on July 6, 1999. This paper is part of the *Journal of Structural Engineering*, Vol. 126, No. 9, September, 2000. ©ASCE, ISSN 0733-9445/00/0009-1026-1032/\$8.00 + \$.50 per page. Paper No. 21326.

yielded. The reactions, member forces, capacity V_{y2} and corresponding deflection Δ_{y2} of the new statically indeterminate truss would be calculated as described above. The total lateral load strength developed at this stage is equal to the sum of V_{y1} and V_{y2} , and the total deflection is equal to the sum of Δ_{y1} and Δ_{y2} .

At this point, either one or both of Members 1 and 4 have fully yielded. Removing the yielded member from the model, the structure reduces to either one of the statically determinate trusses shown in Fig. 1(b). The horizontal load V_{y3} is defined as the force that yields a member in the resulting truss system, with the corresponding deflection defined as Δ_{y3} . Upon reaching this force level, a complete plastic collapse mechanism forms. The ultimate strength of the retrofitted wall is given by the sum of V_{y1} , V_{y2} , and V_{y3} , and the corresponding deflection by the sum of Δ_{y1} , Δ_{y2} , and Δ_{y3} . The resulting load-deflection envelope for a retrofitted wall can be constructed using these values.

Note that gravity loads were not considered in the above analysis. If the steel strips are added as part of a seismic retrofit, the gravity loads would already be resisted by the existing concrete or masonry wall. This can be accounted for in the truss model by reducing the compressive strength of the concrete/masonry of Members 3 and 5 by an amount corresponding to gravity-induced stresses. If the gravity loads are applied after the strips are installed, as is the case in the experimental program reported in the companion paper (Taghdi et al. 2000), then the existing concrete/masonry walls and the new steel strips resist the entire gravity load together. In this case, a simple correction can be introduced to the above procedure. However, for the low gravity forces that are typical for walls, this effect may be negligible.

IMPROVED TRUSS MODEL

While the relatively simple truss model described above captures reasonably well the progress of inelastic behavior and final failure mechanism, it can be improved if additional members are considered. For example, for the wall tested by Taghdi et al. (2000), to account for the presence of vertical reinforcement at midlength, an additional vertical member may be introduced. Furthermore, additional compression struts (Members 6 and 7 in Fig. 2) may have to be introduced, resulting in a truss model that describes inelastic deformability of retrofitted walls more accurately. The improved truss model is then used to conduct the same type of step-by-step analysis described earlier, with increased redundancy. Although this requires a greater computational effort, it remains simple enough so that manual calculations suffice (or, alternatively, a simple elastic analysis computer program may be employed).

Fig. 3 illustrates the calculation steps involved in the improved model, while also providing a comparison with those described earlier for the simple truss model involving a retrofitted concrete wall with a pair of middle bars. Additional locations of vertical reinforcement would permit consideration of models with higher degrees of redundancy. Each successive elastic analysis (on progressively less redundant structures) produces force-displacement data pairs that can be plotted on the force-displacement relationship. The analysis of a model

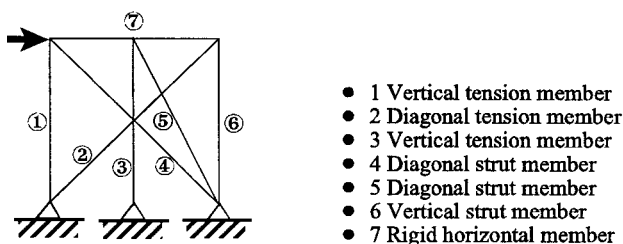

FIG. 2. Improved Truss Model

with a larger number of tension members increases the number of data points that define the force-displacement relationship. Obviously, for a retrofitted unreinforced masonry wall, an improved truss model is not possible.

Note that the above procedure is based on the assumption that the reinforcing bars and the steel strips are detailed to prevent premature buckling at the ends of the wall, as these effects may alter the sequence of yielding. For example, the buckling of steel strips may prevent the wall from sustaining its plastic capacity up to the desired strain (deformation) capacity.

LOWER BOUND METHOD

Assuming elastoplastic material properties and equilibrium in the undeformed configuration, the strength of the retrofitted low-rise walls may also be estimated using the lower bound theorem from the theory of plasticity (Chen and Sohal 1995; Bruneau et al. 1997), which states: Every load computed on the basis of a stable and statically admissible system is not higher than the true ultimate load of the system. Thus, for a given retrofitted wall, this lower bound method provides a conservative estimate of the ultimate strength, without any information on the corresponding deformation capacity.

Considering the equilibrium of the stable free body diagram shown in Fig. 4 for a wall with three rows of vertical reinforcement, and assuming that yielding takes place in all tension members (i.e., all diagonal steel strips and vertical steel elements), the summation of moments due to the internal and external forces about point O gives an equation with a single unknown. Solving this equation gives a lower bound value for the ultimate horizontal lateral load capacity of a retrofitted wall, V_u , of

$$V_u = \frac{A_v f_{yp} d_v + (A_d f_{yp} d_v \sin \theta + 0.5 P d_v + \sum A_{shi} f_{yh} h_i + \sum A_{si} f_y d_i)}{H} \quad (1)$$

where A_v = area of vertical steel strips in tension; A_d = area of diagonal steel strips in tension; A_{shi} and A_{si} = areas of the i th horizontal and vertical pair of reinforcing bars, respectively; f_{yp} , f_{yh} , and f_y = yield strength of steel strips, horizontal rebars, and vertical rebars, respectively; d_i and h_i = lever arms of the i th pair of reinforcing bars; and d_v = distance between the vertical steel strips. All other values are the geometrical dimensions indicated in Fig. 4.

Note that the increase in lateral load resistance, ΔV , can be expressed by

$$\Delta V = V_u - V_{uo} \quad (2)$$

where V_{uo} = original (unretrofitted) capacity of the wall; and V_u = new desired strength. For design, if ΔV is conservatively taken to be equal to the horizontal component of the force in diagonal steel strips

$$V_u - V_{uo} = A_d f_{yp} \cos \theta \quad (3)$$

and

$$A_d = \frac{V_u - V_{uo}}{f_{yp} \cos \theta} \quad (4)$$

Substituting (4) into (1) gives

$$A_v = \frac{V_u H - (V_u - V_{uo}) \tan \theta d_v - 0.5 P d_v - \sum A_{shi} f_{yh} h_i - \sum A_{si} f_y d_i}{f_{yp} d_v} \quad (5)$$

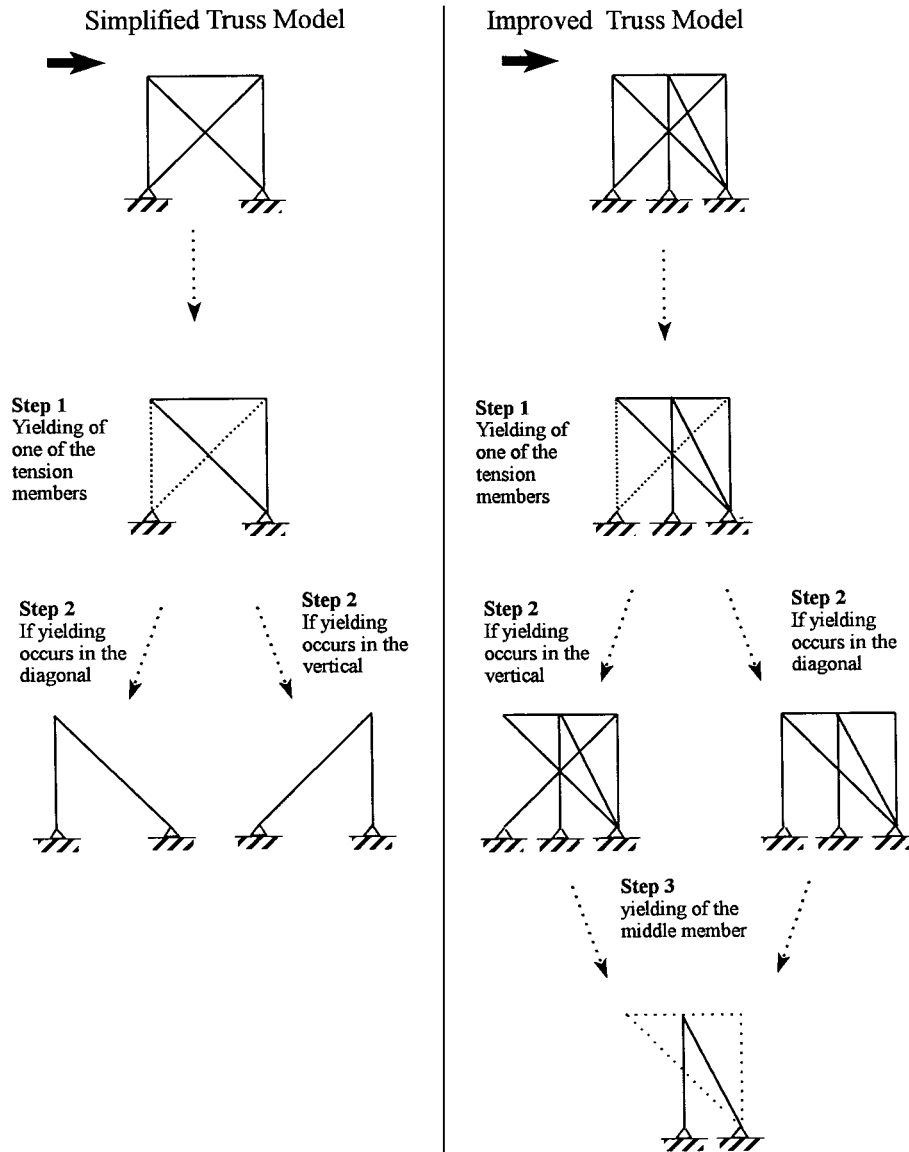

FIG. 3. Yielding Sequence of Tension Members in Simplified and Improved Truss Models

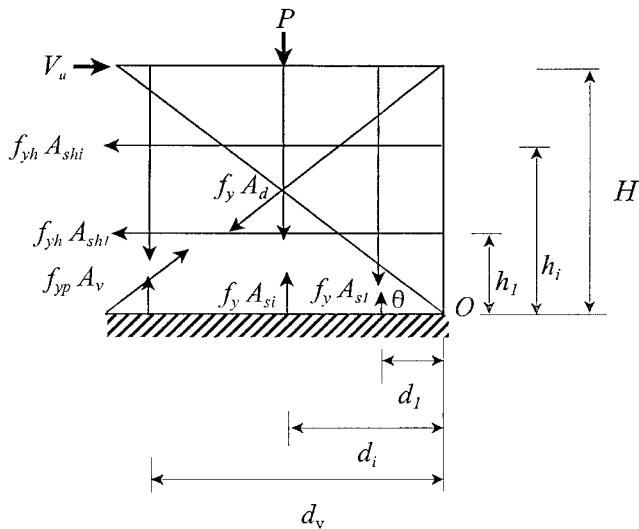

FIG. 4. Assumed Equilibrium for Lower Bound Method

which can be used in preliminary design to determine the steel strip sizes needed for the seismic retrofit of nonductile low-rise walls.

VALIDATION OF PROPOSED MODELS

Force-displacement relationships computed using the two truss models described above have been compared with the experimentally obtained envelopes of the lateral force–horizontal displacement relationships for the three retrofitted walls tested by Taghdi et al. (2000). These results are presented in Figs. 5–7 for Walls 9R, 10R, and 11R, respectively. The ultimate strength calculated using the lower bound method is indicated by solid thick horizontal lines in the figures. Both truss models provide good correlations with test data and can be considered effective analytical tools. The improved truss model provides information over a longer inelastic deformation range. All lower-bound strength calculations provide conservative yet considerably accurate estimates of the ultimate strength.

EFFECTS OF STRUT WIDTHS ON TRUSS MODELS

The effective width of the concrete/masonry considered in calculating the strength and stiffness of compression struts was

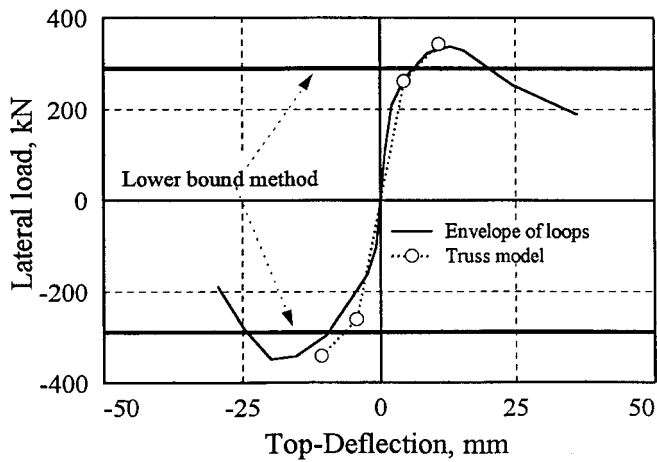

FIG. 5. Comparison of Truss Analysis with Experimental Results for Wall 9R (Retrofitted URM Wall)

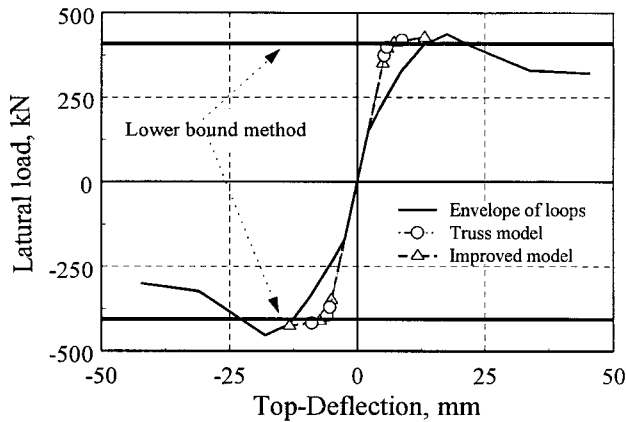

FIG. 6. Comparison of Truss Analysis with Experimental Results for Wall 10R (Retrofitted PRM Wall)

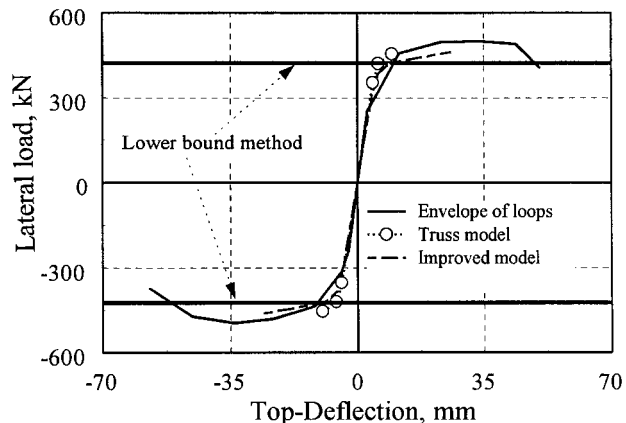

FIG. 7. Comparison of Truss Analysis with Experimental Results for Wall 11R (Retrofitted RC Wall)

taken equal to the steel strip width for the diagonal elements and one-tenth of the length of the wall for the vertical elements. For the effective width of diagonal struts, a range of values were recommended by other researchers in the past. For example, for truss models used in the analysis of infilled frames, it was recommended that the strut width be taken as one-third of the diagonal wall length (Drysdale et al. 1994). The New Zealand Code specifies a diagonal strut width equal to one-quarter of the infill length (Drysdale et al. 1994). Paulay et al. (1992) used a higher value of one-quarter of the diagonal length. A sensitivity analysis was conducted in the current study to determine a reasonable strut width for use in truss

models. The results showed that the resultant force displacement curves were not affected by diagonal strut widths when they varied between approximately one-eighth and one-half of the wall length. A conservative value of approximately one-eighth of the length of the wall has therefore been adopted in the current investigation.

Guidance for the effective width of vertical struts is not available in the literature. The sensitivity of this width to the distribution of forces among the truss members was investigated. This was done by comparing force-displacement relationships obtained by using truss models with a range of concrete/masonry effective width values for the vertical struts, while keeping the steel strip size constant and equal to the value used in the experiments of Taghdi et al. (2000).

Figs. 8(a and b) and 9 show the results for different vertical strut widths for Walls 9R, 10R, and 11R, respectively. Differences are insignificant and the strut width does not appear to be a significant parameter. Thus, using one-tenth of the wall length for vertical compressive struts was found to be satisfactory.

RETROFIT DESIGN PROCEDURE

The following seismic retrofit design procedure is proposed to ensure the adequacy of both strength and displacement capacities in walls:

1. Determine the code-specified lateral seismic force for seismic retrofit.
2. Use (4) and (5) to find the size of the vertical and diagonal steel strips needed to resist this force.
3. Select an appropriate truss model, and use the step-by-step procedure described earlier to compute the load-deflection relationship of retrofitted wall.
4. Check that the ultimate displacement (δ_u) calculated in step 3 is less than the maximum displacement (δ_{max}) expected from the design earthquake (i.e., the displacement demand). If $\delta_u \geq \delta_{max}$, then the wall has sufficient ductility. If not, the design must be modified. Further research would be required to determine how the steel strip

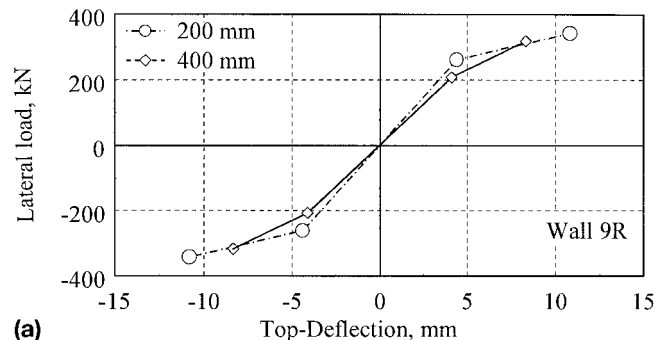

(a)

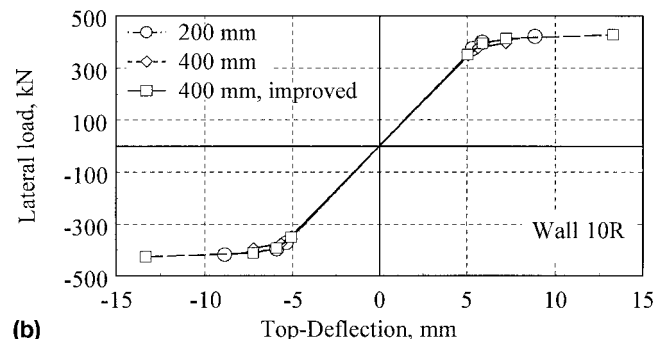

(b)

FIG. 8. Comparison of Truss Analyses Considering Different Vertical Strut Widths for: (a) Wall 9R; (b) Wall 10R

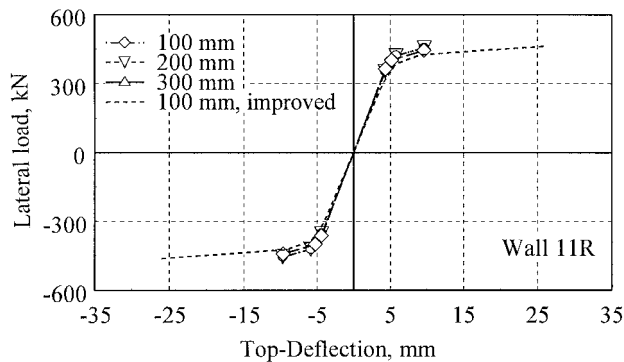

FIG. 9. Comparison of Truss Analyses Considering Different Vertical Strut Widths for Wall 11R

design could be modified to achieve larger drifts. Note, however, that for the stiff low-rise shear walls considered here, displacement demand is usually small and thus very unlikely to exceed the ultimate displacement capacity in excess of 1% exhibited by all retrofitted walls (Taghdi et al. 2000).

5. Find the required spacing of the through-thickness bolts, limiting KL/r to 95 and 65 for staggered and unstaggered bolts, respectively, to remain within the limits of experimentally validated designs. This ensures that the steel strips develop compression yielding prior to their plastic buckling between the bolts. Note that the length L is the diagonal distance between the staggered bolts. $K = 0.5$ can be used here.
6. Design the connections of the steel strip system to foundation and roof to ensure that they are able to develop 1.5 times the nominal force that can be developed in the yielding strips.

The above approach is conservative because the maximum deflection calculated in step 3 is less than the ultimate drift capacity observed experimentally. This is the shortcoming of step-by-step analyses using the proposed truss models, and it particularly penalizes unreinforced masonry walls, as shown in Fig. 5.

Furthermore, to ensure proper detailing, it is recommended that:

1. Through-thickness bolts be placed between the end wall face and the vertical bars in reinforced concrete/masonry walls to provide lateral support against bar buckling at that location.
2. All through-thickness bolts are only lightly pretensioned (i.e., torqued) to avoid damaging the masonry wall.
3. Steel strips be placed on both sides of the walls to avoid out-of-plane movement due to strength and stiffness eccentricity and to increase wall redundancy.
4. Low strength steel is used for the strips to allow yielding of tension elements (steel strips and/or reinforcing bars) prior to the crushing of vertical and diagonal compression struts.

DESIGN EXAMPLE

The recommended design procedure is illustrated for the single-story building shown in Fig. 10. The walls are to be retrofitted using the steel-strip system shown in Fig. 11. The building is 38.4×48 m in plan and has a 4.8 m clear height. Lateral load resistance is provided by four reinforced concrete end walls in each direction. The length of each wall is 4.8 m. A 300 mm thick reinforced concrete slab is used to provide parking on the roof. All walls are 100 mm thick. The concrete compressive strength is 25 MPa and the reinforcement grade is 400 MPa. The building is assumed to be in seismic Zone 5 of the National Building Code of Canada (NBCC) for both seismic accelerations and velocities.

The NBCC equivalent static seismic base shear, V , is given by

$$V = \frac{UV_e}{R} = \frac{U(vSIFW)}{R} \quad (6)$$

where v = seismic zonal velocity; S = seismic response factor; I = importance factor (taken equal to 1.0 here); F = foundation factor (also taken as 1.0 here); W = total reactive weight; U = calibration factor, equal to 0.6; and R = force modification factor.

For this example building, the weight of the roof, W_1 , is $0.3 \text{ m} \times 48.0 \text{ m} \times 38.4 \text{ m} \times 24.0 \text{ kN/m}^3 = 13,271 \text{ kN}$; the weight of the upper half of all wall, W_2 , is $0.1 \text{ m} \times 24.0 \text{ kN/m}^3 \times 0.5 \times 4.8 \text{ m} \times 4.8 \text{ m} \times 8 = 221 \text{ kN}$; and the weight due to 25% of the snow load, W_3 , is $0.25 \times 48.0 \text{ m} \times 38.4 \text{ m} \times 2.0 \text{ kPa} = 922 \text{ kN}$. Total reactive weight is thus $W = W_1 + W_2 + W_3 = 14,414 \text{ kN}$.

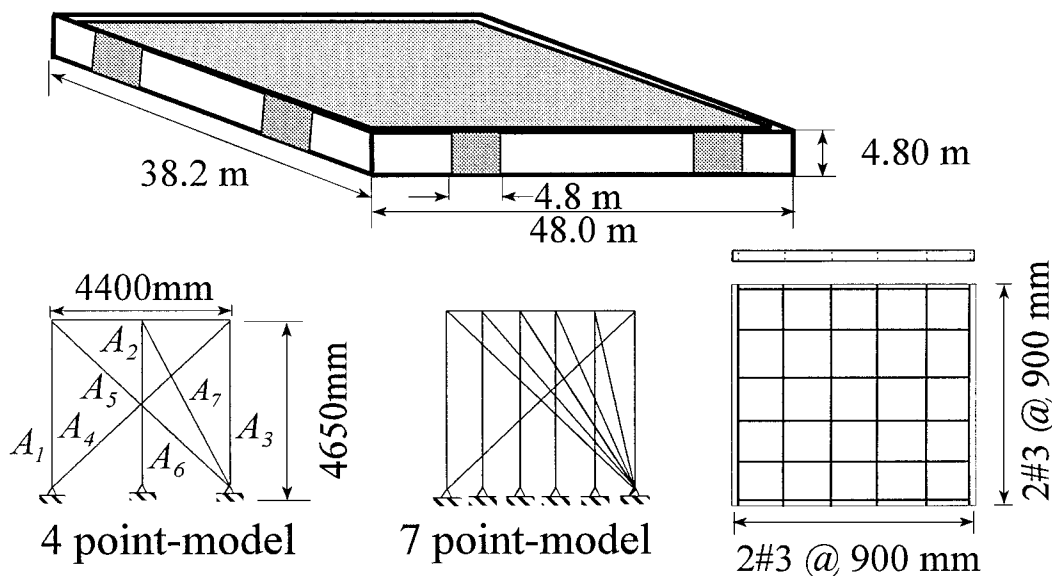

FIG. 10. Design Example of Single-Story Building

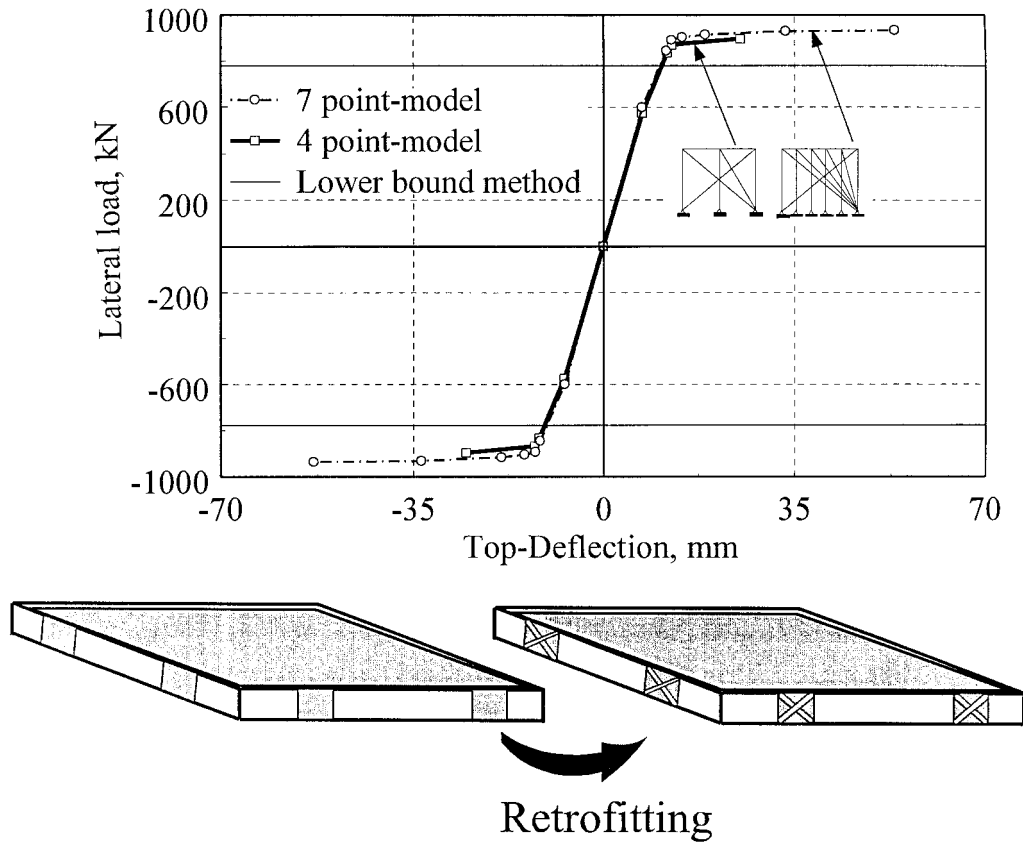

FIG. 11. Retrofitting Single-Story Building Using Steel Strip System

For seismic velocity-related Zone 5, the peak ground velocity, v_s , is 0.3. The period of the building is estimated as T ($0.09h_n/\sqrt{D_s}$), where h_n = story height to the roof level and D_s is taken as the length of the building, giving for each of the building's principal directions:

$$T = \frac{0.09(4.95)}{\sqrt{38.4}} = 0.072 \text{ s and } T = \frac{0.09(4.95)}{\sqrt{48}} = 0.064 \text{ s} \quad (7)$$

The corresponding seismic response factor, S , for both periods is 3.0. The selection of the force modification factor, R , requires judgment given that only the conventional structural systems are included in the Force Modification Factors table in the NBCC (*National* 1995). Based on the results of the experimental study by Taghdi et al. (2000), it appears that walls retrofitted using steel strips have exhibited a ductility and hysteretic behavior somewhat between that of a ductile braced frame and a nominally ductile wall, respectively assigned force modification factors of 3 and 2 by the NBCC. Hence, an average value of $R = 2.5$ is chosen here. This gives a minimum lateral seismic force of $V = (0.3)(3)(1.0)(1.0)$ (14,414 kN)(0.6)/2.5 = 3,113 kN, and a seismic base shear tributary to each wall of $V_u = V/4 = 778$ kN.

The lateral load capacity of the existing (unretrofitted) concrete wall V_{uo} , is calculated to be 300 kN using a model proposed by Doostdar and Saatcioglu (1998) and taking into account the gravity loads applied to the walls. Then, using (4) and (5), A_d and A_v can be calculated as

$$A_d = \frac{(778 \text{ kN} - 300 \text{ kN})10^3}{(225 \text{ MPa}) \cos 46} = 3,058 \text{ mm}^2 \quad (8)$$

$$A_v = \frac{[(778 \text{ kN})(4.65 \text{ m}) - (778 \text{ kN} - 300 \text{ kN})(4.4 \text{ m})\tan 46 - 535 \text{ kNm}10^6]}{[(225 \text{ MPa})(4.4 \text{ m})10^3]} = 914 \text{ mm}^2 \quad (9)$$

Because the effect of the gravity load has been considered in calculating the capacity of the unretrofitted wall, it should not be included in (5). Diagonal and vertical steel strips can be sized to satisfy (8) and (9).

Fig. 11 shows the resulting force-displacement curves obtained using two versions of the improved truss models. For the four-member model considered, the following member areas are used:

- A_1 (Total of end steel bars area and net area of vertical steel strips) = $858 + 142 \times 2 = 1,142 \text{ mm}^2$
- $n = E_s/E_c$, $n = 7.2$, $A_2 = (2,000 \times 300/7.2) + .0025 \times 2,000 \times 300 = 84,833 \text{ mm}^2$
- A_3 (Area of vertical compressive strut) = $142 \times 2 + 858 + 450 \times 100/7.2 = 7,392 \text{ mm}^2$
- A_4 (Net area of diagonal steel strips) = $3,576 \text{ mm}^2$
- A_5 (Area of diagonal strut) = $3,576 + 470 \times 100/7.2 = 10,104 \text{ mm}^2$
- $A_6 = 142 \times 2 = 284 \text{ mm}^2$, $A_7 = 100 \times 100/7.2 = 1,389 \text{ mm}^2$

Member areas for the seven-member model are: $A_1 = 1,000 \text{ mm}^2$; $A_2 = A_3 = A_4 = A_5 = 142 \text{ mm}^2$; $A_6 = 7,250 \text{ mm}^2$; $A_7 = 84,833 \text{ mm}^2$; $A_8 = 10,104 \text{ mm}^2$; $A_9 = A_{10} = A_{11} = 100 \times 100/7.2 = 1,389 \text{ mm}^2$; $A_{12} = 3,576 \text{ mm}^2$; where A_1, A_2, A_3, A_4, A_5 , and A_6 = vertical members from left to right; A_7 = top member; A_8 = tension diagonal member; and A_9, A_{10}, A_{11} , and A_{12} = four compression struts from right to left.

In the first case, the distributed vertical reinforcing bars were lumped at three locations, as shown in Fig. 10. In the second case, each reinforcing bar was left at its actual position. These models permitted the calculation of four and seven force-displacement points prior to the development of the plastic collapse mechanism. Clearly, the improved model better

describes the behavior and gives more information about the inelastic deformability of this retrofitted wall.

CONCLUSIONS

Simple truss models were used to predict strength and ductility of low-rise walls retrofitted with diagonal and vertical steel strips. A step-by-step analysis procedure was presented for design purposes. The analysis of walls utilizing the procedure described provided correct descriptions of the sequence of yielding among members, and it captured accurately the global lateral force–lateral displacement relationships. The models provided analytical results that are in good agreement with those obtained experimentally. It was found that the ultimate shear strength of walls retrofitted with steel strips could also be obtained using a lower bound approach and a simple model at the formation of plastic collapse mechanism. The models described in the paper allow the formulation of a simple design procedure that engineers may employ in retrofitting existing nonductile low-rise walls.

APPENDIX. REFERENCES

- Bruneau, M., Uang, C. M., and Whittaker, A. (1997). *Ductile design of steel structures*, McGraw-Hill, New York.
- Chen, W. F., and Sohal, I. (1995). *Plastic design and second-order analysis of steel frames*, Springer-Verlag, New York.
- Doostdar, H. M., and Saatcioglu, M. (1998). "Inelastic shear behavior of reinforced concrete walls." *Res. Rep. No. OCEERC 98-23*, Dept. of Civ. Engrg., University of Ottawa, Ottawa.
- Drysdale, R. G., Hamid, A. A., and Baker, L. R. (1994). *Masonry structures, behavior and design*, Prentice-Hall, Englewood Cliffs, N.J.
- Handbook of steel construction*. (1991). 5th Ed., Canadian Institute of Steel Construction, Markham, Canada.
- National Building Code of Canada*. (1995). National Research Council of Canada, Ottawa.
- Pauley, T., and Priestley, M. J. N. (1992). *Seismic design of reinforced concrete and masonry buildings*, Wiley, New York.
- Taghdi, M. (1998). "Seismic retrofitting of existing low-rise masonry and concrete walls by steel strips." PhD thesis, Dept. of Civ. Engrg., University of Ottawa, Ottawa.
- Taghdi, M., Bruneau, M., and Saatcioglu, M. (2000). "Seismic retrofitting of low-rise masonry and concrete walls using steel strips." *J. Struct. Engrg.*, ASCE, 126(9), 1017–1025.